

PREFERRED ENGINEERING

modular shielding walls & vaults

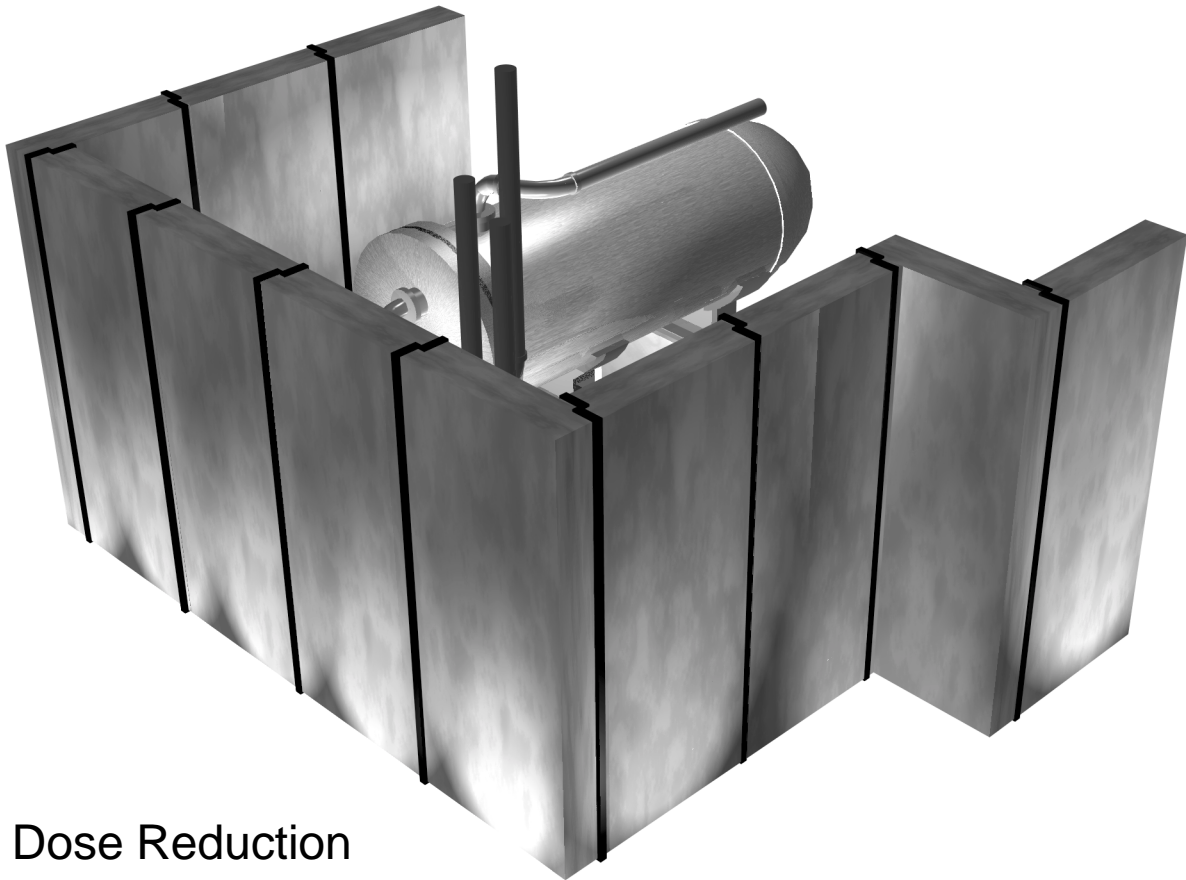

- Dose Reduction
- “Hot” Material Storage
- Radiation Containment
- Shielding For Occupied Space

PREFERRED ENGINEERING

a subsidiary of Preferred Utilities Mfg. Corp.

31-35 South St. ● Danbury ● CT ● 06810

phone: (203)743-6741 ● fax: (203) 798-7313

peinfo@preferred-mfg.com ● <http://www.preferred-mfg.com/pe/>

FLEXIBILITY

Using advanced design and engineering techniques, Preferred can offer engineered wall systems and vaults for maximum shielding; all of which are designed to fit your specific size, shape and shielding requirements.

FEATURES

- Complete flexibility... these vault systems can be easily modified or relocated as your needs change.
- High density concrete panel construction results in excellent shielding characteristics.
- Short design and installation cycle. Vaults are installed by trained crews in days with a minimum of disruption.
- Vault interiors can be fitted with sloped floors and liner plates to contain leakage.
- Shop fabrication delivers high quality and reduces on-site construction issues (i.e. dust, disruption, and cleanup).

DESIGN

- Vaults and walls are designed to meet your seismic criteria.
- Interlocking joints provide stability and minimize shine.
- Vaults can be engineered to accept a variety of door types.

OPTIONS

- Various thicknesses 4" TO 12"
- Catalyzed epoxy finish available
- Panel widths 1' to 5' : Panel heights 1' to 14'
- Electrical and utility pass-thru accommodations

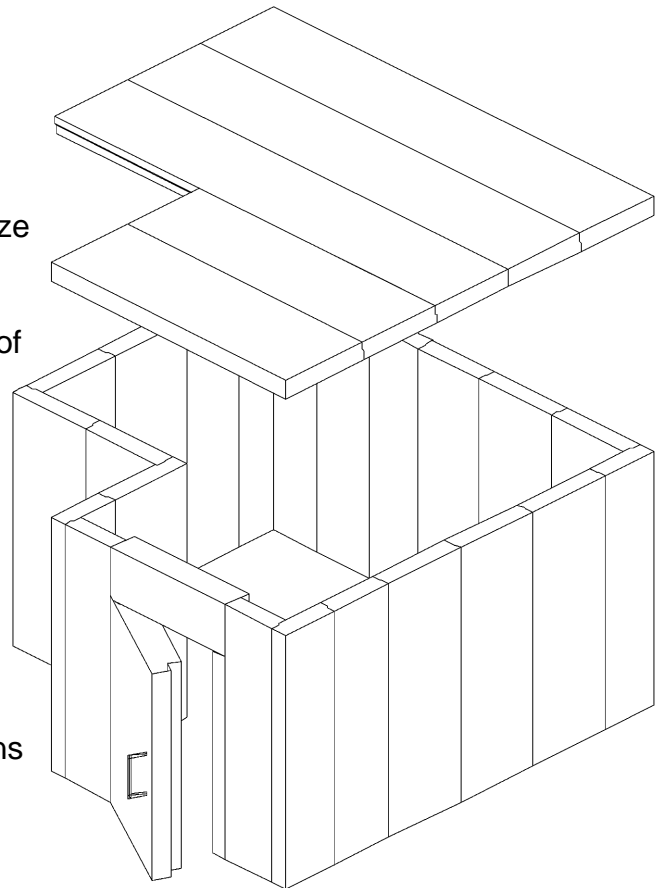

PREFERRED ENGINEERING

phone: (203)743-6741 ● fax: (203) 798-7313
peinfo@preferred-mfg.com ● <http://www.preferred-mfg.com/pe/>